

Many people have attempted to replicate Tariel's work, and a self-powered replication can be seen at <http://www.youtube.com/watch?v=rbkvXoDfk7g>.

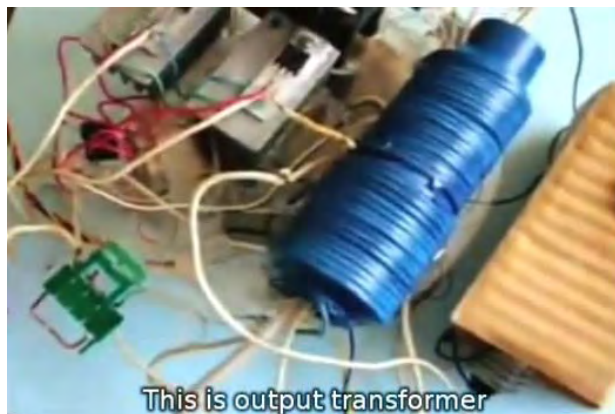

The Kapanadze coil analysed by William J. McFreey.

May 2012

By releasing the videos of his electromechanical device, Kapanadze left little doubt (to the average physicist) as to how his and some other "overunity" devices work. The following articles explain this working principle in detail.

This analysis is devoted to the Kapanadze coil, which is a close relative of his lesser-known electromechanical device. The main ingredients for achieving the Tariel Kapanadze (Michel Meyer, Steven Mark, Floyd Sweet, "SR193"...) effect are Nuclear Magnetic Resonance ("NMR") which generates the initial fast-moving particles (e.g. electrons), avalanche particle multiplication (induced transmutation) and a magnetic field of appropriate strength to confine and guide these particles within a conductive material.

It is believed that copper or an alloy of copper or iron are Kapanadze's materials of choice and that material is used as fuel when it undergoes stimulated transmutation. The reason is that copper has many isotopes with half-life times spanning from nanoseconds to tens of hours (http://en.wikipedia.org/wiki/Isotopes_of_copper). Copper isotopes with atomic masses below 63 tend to undergo β^+ decay, while copper isotopes with masses above 65 tend to decay in β^- mode. Many Copper isotopes have non-zero nuclear spin and hence can be manipulated or stimulated through Nuclear Magnetic Resonance. However, this statement also applies to Zinc, Iron and many other metallic elements. Thus these elements, and alloys of these elements such as brass, can also be used as fuel.

Enhanced β -decay under NMR stimulation is known and actually used in scientific research in so called 'beta-NMR spectrometers' in which the nuclear spin precession signal is detected through the beta decay of a radioactive nucleus (<http://bnmr.triumf.ca/?file=default>).

The main task in creating a working device, using these principles is to create a suitable physical layout which allows an extremely high current in the conductive (or even non-conductive) multiplication disc or ring, to be excited and fully controlled, and so, not only create torque but also, useful electrical power.

The exact construction of the Kapanadze coil is difficult to infer as the details of the inner geometry and materials used in the coil are generally hidden. However, knowing the working principles stated above, it is possible to present an effective, generalised working geometry.

The most logical starting point would be to take the exact geometry of the electro-mechanical device and wrap a winding, L2, around the perimeter of one or both of the discs as shown in Fig.1. As concluded in the article below, the current created by the orbiting charged particles modifies and reduces the magnetic field in the discs, eventually pushing the cyclotron resonance orbit beyond the perimeter of the disc. This results in self-termination of the pulse. Thus, the multiplication current is self-quenching. There is pulsating current in the disc or discs, and each pulse is initiated by a short wide-spectrum pulse applied to coil L1. This pulsating current is then coupled inductively through windings, L2a/L2b and delivered as electrical output.

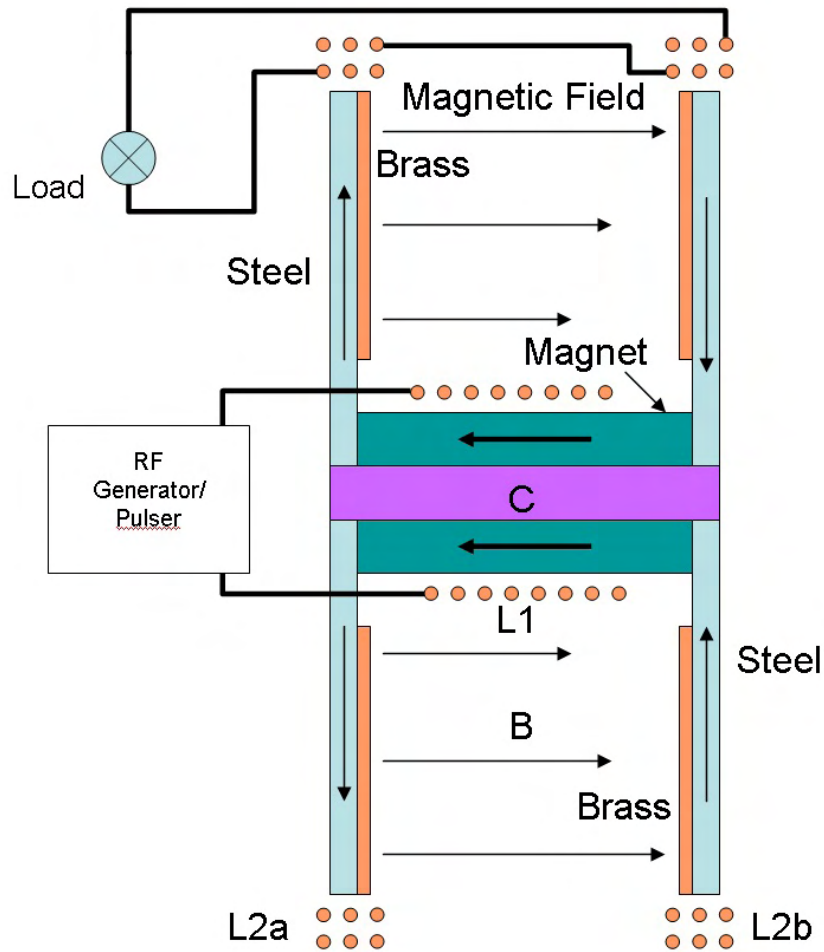

**Fig. 1. Possible configuration of power pick-up from the spool type device.
The component marked 'C' centres and holds the elements together.**

This arrangement was implemented on a smaller scale, by Steven Mark in his first demonstrated device: the "Small TPU". The three pictures of this device, shown below, are a clear demonstration of this idea. The second picture with the device upside down, shows the exposed connecting wires to the (hidden) coil L1.

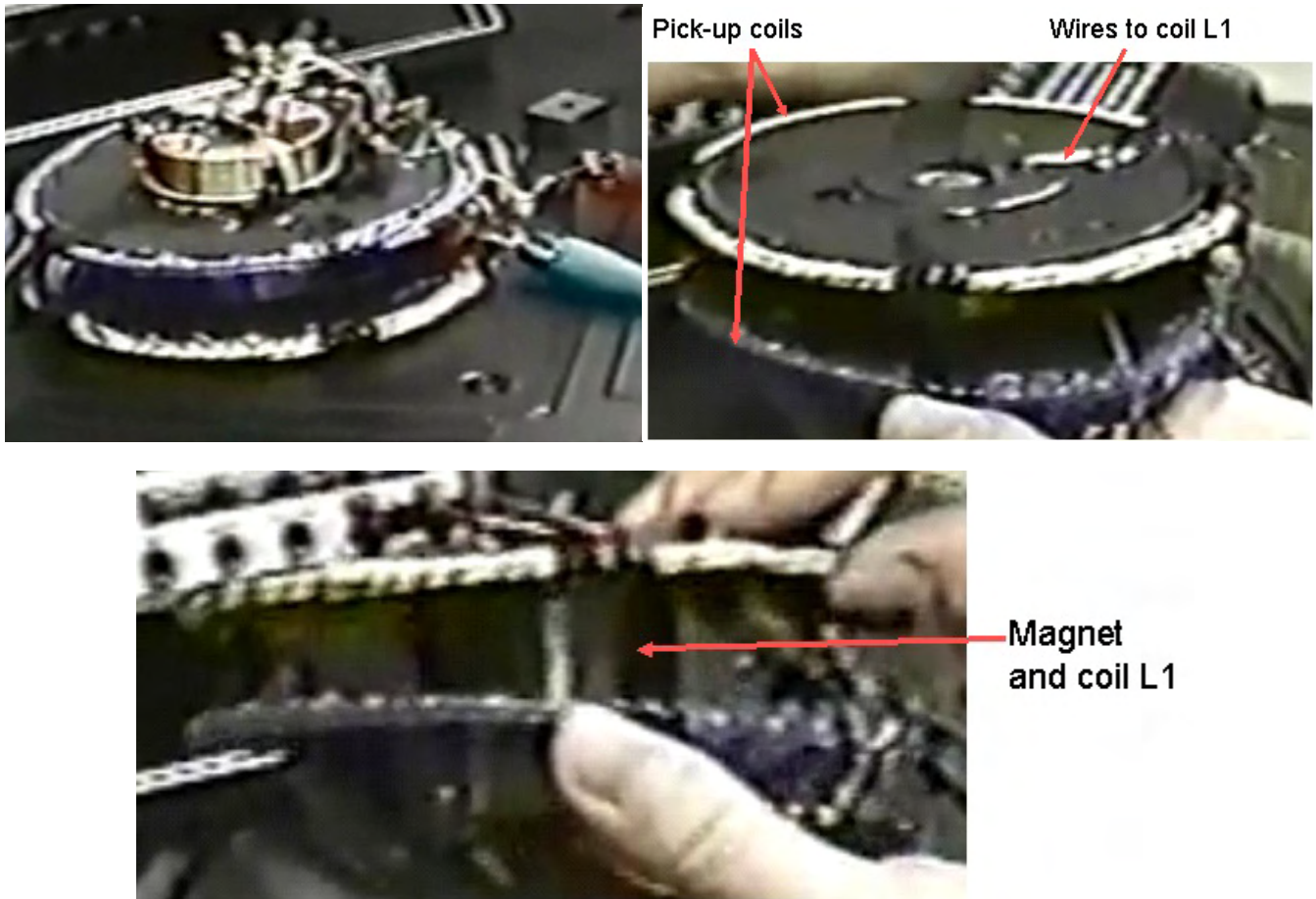

Fig.2. Steven Mark's implementation of the spool type energy coil. The toroid in the top centre forms a filter. The helical winding on the pick-up coils is for holding the wires together.

In this device, as Steven Mark puts it, "kicks" of small current applied to coil L1, result in big "kicks" of the multiplication current in the discs, which in turn, are inductively coupled to the windings on the perimeter of the discs. This spool and coil layout is not the only possible arrangement, as shown later on by Steven. In fact, this small version of the spool type device did not work very well. He could only demonstrate voltage output from this device and not current. From the bottom picture in Fig.2 it can be seen that this device had problems with circular symmetry of the magnetic field. One of the disks had to be deformed to compensate for this asymmetry.

To get a better insight into inner workings of this type of device, let us calculate the magnetic field, "B", necessary to confine fast-moving charged particles in orbits of various radii as well as the NMR-exciting frequencies needed to generate the initial fast, charged particles.

Assuming the effective speed of emitted electrons ($q = 1.602E-19$ C , $m_0 = 9.11E-31$ kg) to be $v = 270,000$ km/s in a circular path of radius "r". Then:

$$B = vml(qr) , \quad m = \frac{m_0}{\sqrt{1 - (v/c)^2}} ,$$

where m_0 is the mass of an electron at rest and c is the speed of light in vacuum.

Tariel Kapanadze's electromechanical device has a large disc radius of 250 mm, and so the corresponding value of B can be small: 141 Gauss = 14.1 mT. The NMR frequency for Cu^{65} and Zn^{67} (in brass) at this value of magnetic field would be 171 kHz and 37.8 kHz respectively.

In contrast to this, the disc radius of Steven's "small TPU" is ... small, around 60 mm. Consequently, the magnetic field required in this case is considerably higher, 587 Gauss, and the frequencies are therefore higher, 711 kHz for Cu^{65} and 156.7 kHz for Zn^{67} .

Because of this, the penetration of the Radio-Frequency magnetic field within the discs in these two cases will be quite different, and so the efficiency of the fast-particle generation will be also different.

The efficiency of Radio-Frequency magnetic field penetration into a material is governed by the skin-effect which occurs when eddy currents flowing in an object at any depth, produce magnetic fields which oppose the primary field, thus reducing the net magnetic field intensity. The depth to which a magnetic field penetrates into a material is affected by the frequency of the excitation field, the electrical conductivity and the magnetic permeability of the material. The depth of penetration decreases with increasing frequency and increasing conductivity (1/resistivity) and with the magnetic permeability. The depth at which eddy current density has decreased to 1/e, or about 37% of the surface density, is called the "standard depth of penetration", δ .

$$\delta = \sqrt{\frac{2\rho}{(2\pi f)(\mu_0\mu_r)}} \approx 503 \sqrt{\frac{\rho}{\mu_r f}}$$

where

δ = the skin depth in metres,

μ_0 = the permeability of vacuum ($4\pi \times 10^{-7}$ H/m),

μ_r = the relative permeability of the medium

ρ = the resistivity of the medium in $\Omega \cdot m$,

f = the frequency of the current in Hz

The table below lists resistivity and magnetic permeability of selected materials.

Table 1

Material	Chemical	Bulk	Relative Permeability μ/μ_0
	Formula	Resistivity @20C $\mu\Omega \times cm$ ($\Omega \times 10^{-8}m$)	
Aluminium	Al	2.65	1
Brass	Cu70/Zn30	7	1
Bronze	Cu89/Sn11	15	1
Chromium	Cr	13.2	1
Copper	Cu	1.69	1
Dural	Al95/Cu 4/Mg 1	5	1
Iron	Fe	10.1	500
mu-Metal		47	30,000
Nickel	Ni	6.9	200
Palladium	Pd	10.8	1
Silver	Ag	1.63	1
Steel (nonmagnetic)	Fe/Cr	70	1.03
Tin (pure)	Sn	12.6	1
Zinc	Zn	5.96	1

Thus, δ for the brass disc of R=25 cm will be 0.685 mm, while for the same disc of R=6 cm it will only be 0.337 mm, assuming Zn⁶⁷ as the resonating element and particle emitter.

This might have been one of the reasons why the "Small TPU" did not work very well. Therefore, Steven Mark's next device, the "Open TPU" (Fig.3), had a larger diameter to allow better penetration of the high-frequency magnetic field into the multiplication material. In the "Open TPU" the standing magnetic field was generated by two magnets (or stacks of magnets) and was guided by the steel part of the two composite rings of magnetic steel and brass, rather than composite discs. The current "kicks" were applied to the coils wound around the lower of the two composite rings, to excite NMR in brass. The magnetic field created by these coils was still perpendicular to the main (standing) magnetic field, between the rings, penetrating the brass rings. However, in this case it was

parallel to the ring's perimeter rather than its radius. In this device, the extraction of the useful power generated in the brass ring or rings was accomplished by the pick-up coils wound around the magnets.

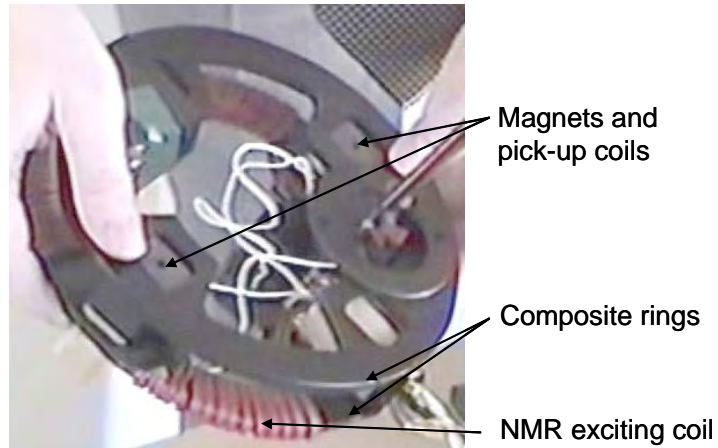

Fig. 3. Open TPU.

This larger Steven Mark device worked significantly better than its predecessor. However, deeper penetration of RF magnetic field into the brass disk or ring can also be accomplished through the increase of Radio Frequency power delivered to the disk. Steven Mark showed this later, implementing small ring (or toroidal) devices. Thus, it is shown here that both Kapanadze and Mark use the same underlying phenomenon.

In the device of Fig.1, the coil L2 does not have to be divided into two sections L2a, L2b. If the radius of the device is not too big, then the spool can be inserted into a tube and the coil L2 can be wound continuously on that tube. This is what might have been done in the vertical aquarium device, Fig. 4. The vertically positioned coil is of significant diameter, larger than any other coil exposed in subsequent demonstrations. The wires leading to the top of the coil are most probably feeding coil L1. The yellow box might be the pulser, a copy of electronics used in the electromechanical device. Since the spool is not rotating here, no intermediate transformer, denoted as T1 in the article below, is necessary.



Fig. 4. Vertical aquarium.

It should be noted that the simplified schematic of the devices shown in Figures 1 to 4 may then look like the diagram shown below (Fig.5). If the details of the conversion part of the device are left out, then the arrangement

of L1/L2, looks just like a transformer, which is in agreement with the patents (WO_2008_103129_A1 and WO_2008_103130_A1). Then, as a result, this device looks very simple.

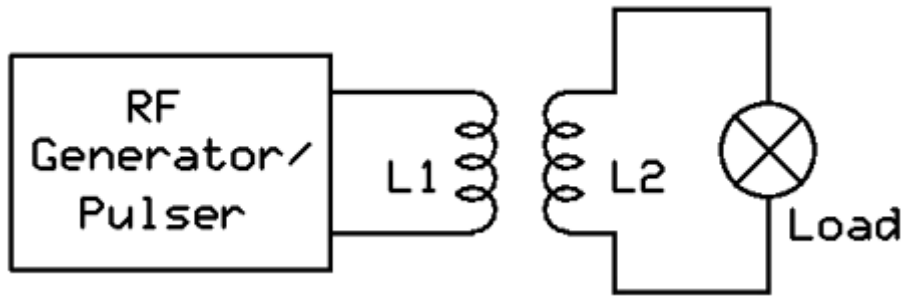

Fig.5. Simplified schematic of the device shown in Fig. 1.

Although the device may look like a transformer, it must be stressed that the energy in L2 does not come from L1, L1 only initiates the conversion process. The energy comes from transmutation of the disk material and manifests itself as a pulse of very high current in the disk or disks. This current produces a magnetic pulse which is inductively coupled by L2. Unfortunately, this magnetic pulse is also spuriously coupled by L1. To alleviate this, coil L1 has to be split into CW and CCW parts.

As mentioned earlier, the output of coil L2 is in the form of very high voltage, low frequency pulses. To reduce the peak voltage of these pulses on the load, it is customary to use a coil in series with the load, such a coil is marked L0 in Fig.6a. This coil has to be wound using well insulated wires to avoid breakdown and discharge damage.

The coil L0 was always exposed in Kapanadze demonstrations, had various shapes and decorations and output wires were always from this coil. The spool was always hidden: in the tin box (2004), inside the green box, under old PCB's, in the plastic box and was not accessible to the spectators. The spark gap, SG, sometimes visible in the demonstrations, connected directly to L2, is simply a voltage spike suppressor.

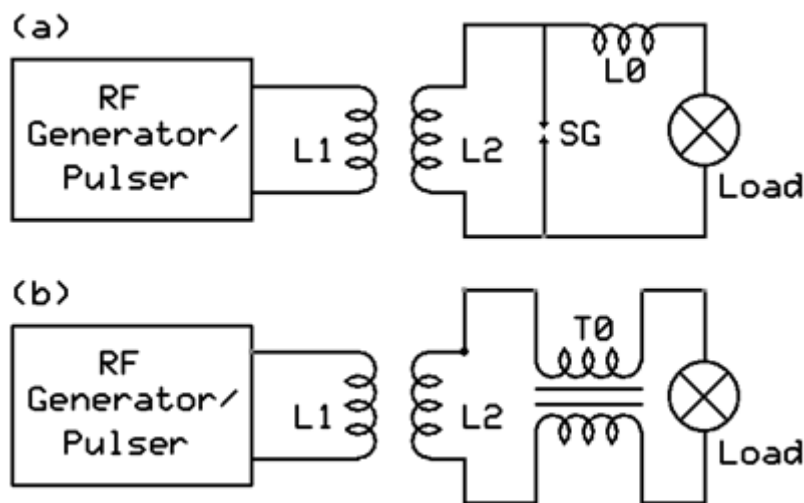

Fig. 6. Reduction of voltage spikes on the load. (a) using a coil, (b) using a toroidal transformer.

Steven Mark relied on a ferrite toroidal transformer, marked T0 in Fig 6b, for voltage spike reduction. This method is much more effective. He never required the spark gap for voltage spike suppression. It must be admitted though, that Mark's devices were not as powerful as Kapanadze's.

In view of the above, the "Green Box" demonstration circuit might have looked like shown in Fig. 7. The "Green Box" hides the RF Generator/Pulser and the "Spool" arrangement with L1 and L2. The shape between L1 and L2 indicates that this is a spool device and that the spool is grounded. The spark-gap, the infamous coil L0, decorated with heavy gage spring-like coil, and the Load were outside the box. The voltage output on the load, despite L0, is still relatively high and pulsed. When the output is transformed to lower voltage in T1, rectified and filtered, it can be used to power low voltage devices or the RF Generator/Pulser. In the "Green Box" demonstration, the input to the Radio Frequency Generator/Pulser was designed to be 220V/50Hz, therefore an inverter was used to close the self-powering loop.

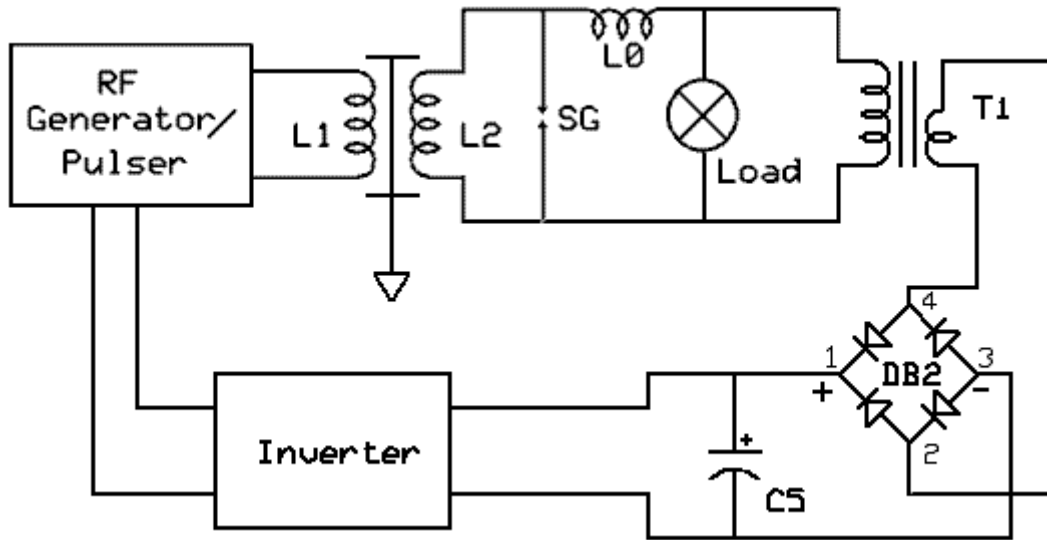

Fig. 7. The "Green box" demonstration.

One of the many possible RF Generator/Pulser implementation circuits is shown in Fig.8:

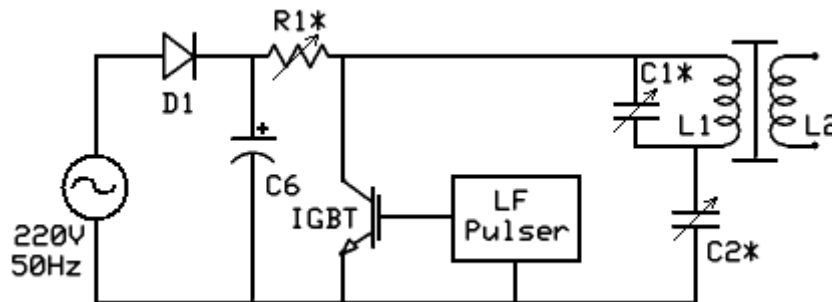

Fig.8. Example circuit for the RF Generator/Pulser. LF Pulser may be LM555 based. Asterisks denote adjustable parts.

The circuit of Fig.8 is very simple. Diode D1 rectifies the mains or the inverter output (a bridge rectifier could also be used here) and stores the energy in C6. Capacitor C2 is charged from C6 through R1 and L1. Energy stored in C2 is periodically discharged by the IGBT transistor which is controlled by a low-frequency pulser running at about 10Hz to produce dense comb of frequencies. The current through L1 during the discharge must be high enough to induce magnetic field oscillations which are capable of exciting Nuclear Magnetic Resonance in the disc. The transistor used here does not have to be of IGBT type, but it must have capabilities which can handle the appropriate voltage and current. Two or more devices might be used in parallel to provide sufficient peak current through L1. Capacitor C2 determines the value of the peak current in the pulse. The LRC circuit consisting of coil L1, capacitor C1 and resistor R1 determines the effective band-width and centre frequency of the dense comb of frequencies for NMR excitation. The excited multiplication current in the disc is always many times higher than that in L1 in a properly built and tuned device. Let us first estimate the peak value of the current through L1 on the basis of measurements visible in Taniel Kapanadze's 2004 "green box" video. At 220 V, the input current was 0.3 Amps which is 66 Watts of input power. The rectified and filtered voltage is then 310 V, and so the input current to the pulser would be 213 milliamps. Assuming a 1% duty cycle for the pulse, this gives 21.3 Amps of peak current through L1. This peak current is, of course, higher for still lower duty cycles.

To approximate the value of the current induced in the multiplication disc, assume that the radius of the multiplication disc is 60 mm and that the avalanche multiplication of carriers starts at a radius of 50 mm, which is 10 mm from the perimeter. The initial magnetic field confining the fast ($v=270\,000\text{ km/s}$) electrons at the initial radius has to be 704.5 Gauss. To increase the confinement radius to the disc radius, just before the avalanche termination, the field has to be reduced to 587 Gauss. The compensating difference of 117.5 Gauss in the field strength has to be provided by the magnetic field of the avalanche current loop. To achieve this field strength, the value of the current in the disc has to reach $I = 2 \times R \times B / \mu_0$ which is 1122 Amps. In this calculation a formula for the magnetic field strength in the centre of the current loop was used.

This method of exciting NMR resonance in the disc material at practically any value of the magnetic field penetrating the disc, relies on creating a wide spectrum of a dense comb of frequencies. For this reason, the

pulsing frequency has to be low, around 10 Hz or even lower, because the width of the NMR resonance is very narrow. This means that most of the harmonic energy created through pulsing is wasted, only one frequency in the comb is actually useful. For this reason one may think of a more efficient way of NMR excitation in the disc material: momentarily generating the exact NMR frequency required at a given magnetic field strength. A field strength which is required for cyclotron resonance. This can be achieved by exciting the coil L1 of Fig.1 with FM modulated, continuous RF signal. In this case, the frequency of the signal is modulated around the anticipated NMR frequency, thus passing through that resonant frequency periodically, each time stimulating NMR and hence fast particle generation. This latter method may prove more effective than the dense comb of frequencies method.

The same effect can be achieved through modulation of the magnetic field strength in the disc, while keeping the excitation frequency constant, as described by Michael Meyer. This method, however, brings additional complications, as the field modulation coil also couples to the magnetic pulses created by the avalanche multiplication phenomenon.

This article deduces that the coils visible in the Kapanadze demonstrations are not responsible for energy conversion. Which raises the question: are coil-shaped energy devices possible at all? The answer is yes, but those shapes are more demanding in material selection for the multiplication ring or disc. In these devices, the magnetic field penetrating the disc or ring has to be rather strong, because the radius of the coil is small. This also means that the Nuclear Magnetic Resonance excitation frequency has to be higher. At high frequency it is difficult for the high-frequency magnetic field to penetrate the disc. Therefore less conductive (non-magnetic) discs may have to be used. Non-magnetic stainless steel which has 10.5% or more Chromium (Cr) and more than 50% Iron (Fe), may be a good candidate for use here. This material has resistivity which is 10 times higher than brass and relative magnetic permittivity which is in the range 1.02 - 1.03.

What about iron, http://en.wikipedia.org/wiki/Isotopes_of_iron, as a multiplication (fuel) material? Iron has even higher resistivity than brass, but unfortunately, very high magnetic permeability of more than 500. Hence, the skin depth is very shallow for iron. Fortunately, magnetic permeability is a function of magnetisation. For iron, and all other ferromagnetic materials, when magnetised to saturation, their relative magnetic permeability approaches a value of 1. This is why, in his patent, Michel Meyer mentions 0.5 T as the minimum magnetic field strength in his iron rod. Above this field strength, iron becomes magnetically saturated. At this field strength, or above, the radius of the cyclotron resonance becomes small, less than 1 cm. The multiplication material can then be in the form of an iron rod.

The device described in Michel Meyer's patent, CZ 284,333, does not have to be exactly the shape shown there and it could be shaped into a "coil-type" device. One such possible implementation is described in Kunel's patent:

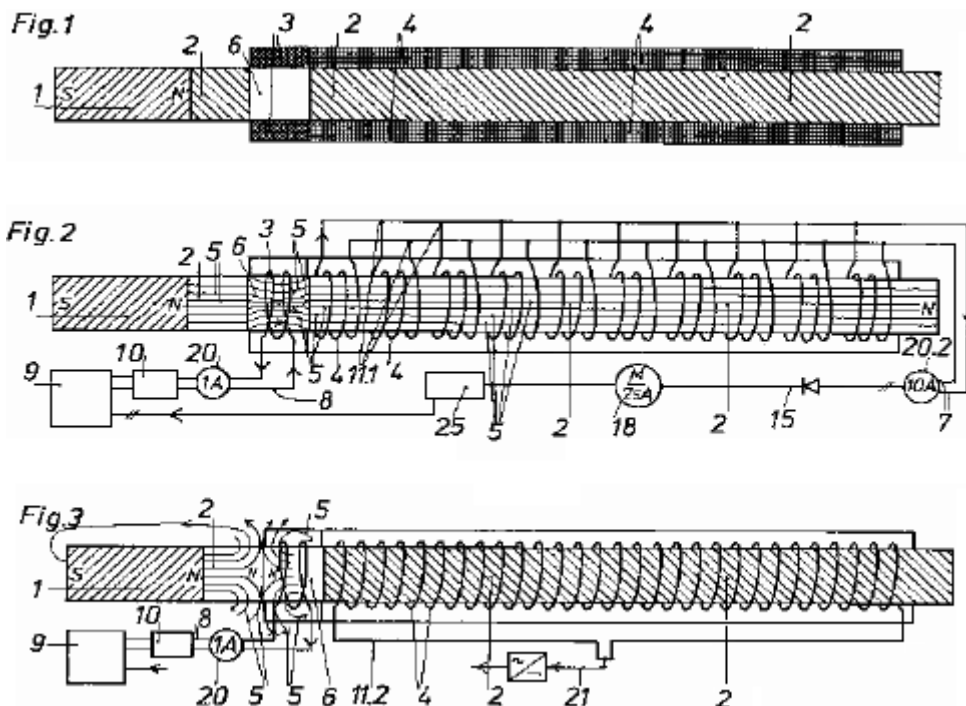

In principle, the multiplication disc does not have to be conductive. The multiplication phenomenon does not rely on conduction electrons, but on fast-moving beta particles. All that is needed, are the initial fast, charged particles and the transmutation material embedded in the magnetic field. In this respect a ferrite ring may also serve the purpose, especially if the ferrite contains a percentage of Zinc or any other element which allows the easy generation of fast-moving particles under NMR stimulation. Ferrite has essentially infinite resistivity, therefore

delivering radio-frequency excitation to the ferrite ring should not be a problem. The biasing magnetic field will be applied perpendicular to the plane of the ring, while the NMR excitation will be parallel to that plane. The fast particle multiplication current will then circulate within the ferrite ring.

If a ferrite ring is chosen as the 'fuel' for the energy coil, then the geometry of the device becomes closer to the device presented by "SR193", which is the only working replication of the Kapanadze-style energy coil at this time. At this point, it is worth remarking that the working schematics of the SR193 device were circulated on the internet for a long time and most of them were almost correct. Only, the correct coil construction and tuning methods were missing.

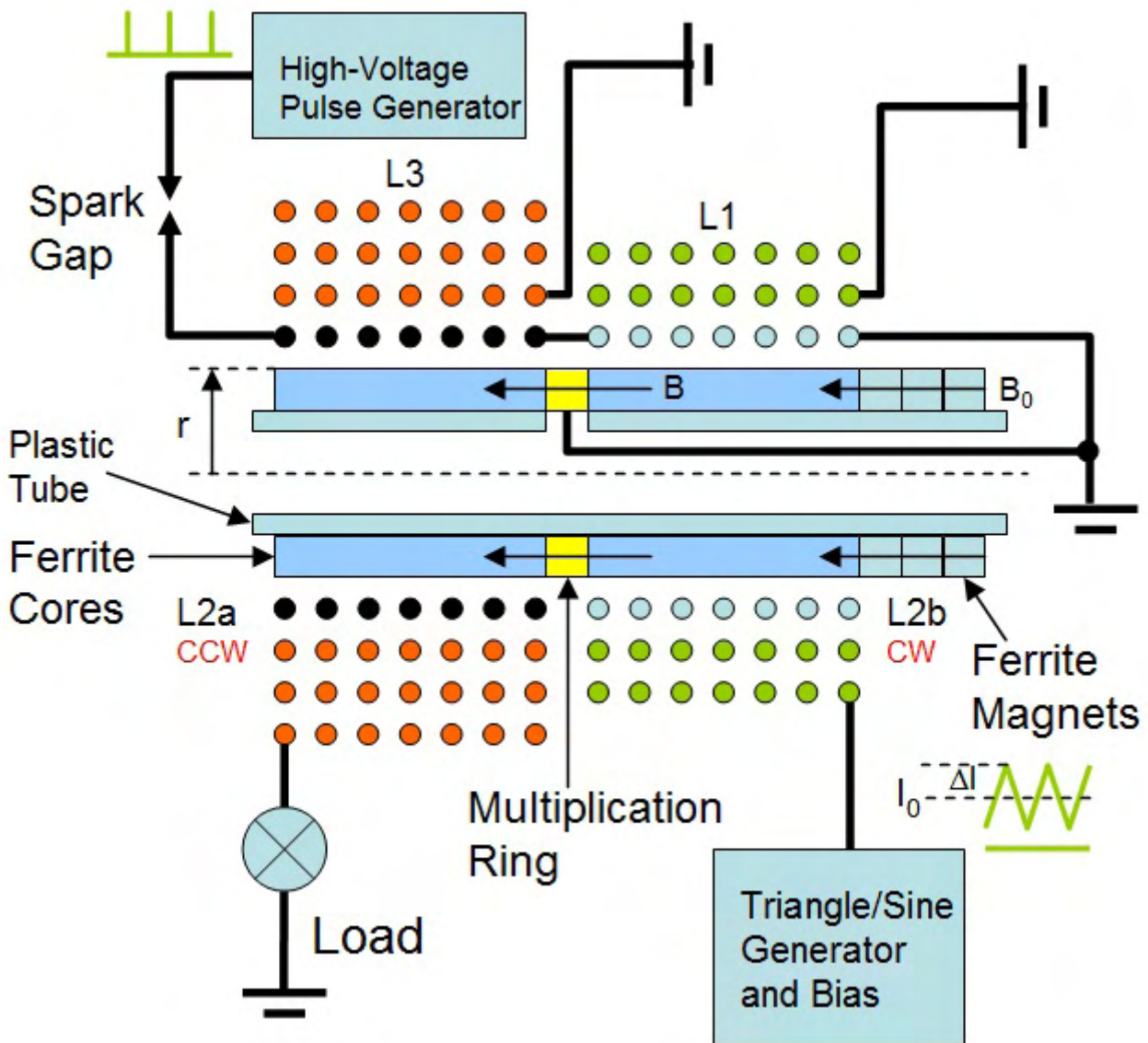

Fig.9 Cross-section of the Kapanadze-like energy device. Some of the actual implementation details may differ from the arrangement shown above, but that will not alter the operation of device. This diagram is not to scale.

As shown here in Fig.9, in this energy device, the coils are all wound on ferrite cores, possibly ferrite rings glued together, but iron powder cores may be used as well. The bottom windings, L2a and L2b, form the NMR excitation coil and are connected in series. These two inner coils L2a and L2b are preferably wound in opposite directions, relative to each other, to create a perpendicular component (relative to the magnetising field B), of the magnetic field in the multiplication ring. L1 is used at low-frequency, to modulate the magnetic field strength within the ferrite multiplication ring. All the components of this device are held together by a plastic tube.

Winding L3 forms a pick-up coil. The ferrite ring magnets attached to the ferrite ring on the right hand side of the central plastic tube, provide the initial, 'biasing' magnetic field, " B_0 ", for the multiplication disc at the centre of the device. Otherwise, this device tunes and works exactly as the device already described in Michael Meyer's patent.

The main secret of the Kapanadze device is the multiplication disc, ring or rod (not necessarily conductive) placed within the coil or coils. It is hard to believe that this piece of physics has been known at least since Michel Meyer's experiments (around 1975) but it is known that Nikola Tesla and later Alfred Hubbard were also aware of this. In the cases of Tesla and Hubbard, the initialising particles needed for the multiplication process were coming from Radium rather than beta-Nuclear Magnetic Resonance.

In the example above, the spark-gap is used to create the (not necessarily dense) set of frequencies which create the Nuclear Magnetic Resonance effect in the ring, via coil L2. Consequently, the spark gap is a very important part of these devices, at least in the beginning. Later, this "quick and dirty" wide-spectrum Radio Frequency generator can be replaced by a more sophisticated semiconductor short-pulse generator. When the comb of frequencies is not dense, the field permeating the multiplication ring has to be modulated in order to ensure that the NMR condition is satisfied. The multiplication ring or disk should be grounded as the transmutation reactions produce a lot of waste charge, especially at high conversion rates. When not grounded, the potential of the ring or disc can get very high and pose the danger of a fatal electric shock.

Please note that all the devices discussed here are similar in the sense that they all share a common source of energy, only slight geometrical and material differences distinguish them. Also, they suffer from a common drawback: the strong magnetic field pulses created by the multiplication current pulses are not only being coupled by the pick-up coil but this field is coupled by all the coils, the only exception being the "Open TPU". This is a major problem because the voltages on the ends of these coils can reach extremely high values. It must be kept in mind that the energy comes from a one-turn coil. The spark-gap insulates the High Voltage pulsing circuit sufficiently from these high voltages in the case shown in Fig.9. The magnetising/modulation circuit is more difficult to insulate. One remedy might be to divide the magnetising/modulation coil L1 into smaller coils each having fewer turns, so that the transformation ratio is reduced and therefore the voltages on their terminals will be lower. This, however, complicates the design and construction of the circuits.

In summary, this article discusses the operational principles and possible physical implementations of Tariel Kapanadze-style and Steven Mark-style coils. The details of the phenomenon behind the operation of these devices are discussed in the following article. As can be seen in different videos on the web, the size, visible number of windings and the diameter of the visible coil varies. The ways in which the coils are decorated to catch the attention of the onlooker also varies. Therefore, this article does not consider these coils as conversion devices, but as filters. The conversion part of the device is always hidden and is shown to be of the spool type transformer. These factors do not change in any way, the operational principles of the device, which is always the cascade multiplication of fast, charged particles within a conductive material of circular cross-section. The charged particles are held in orbit by the Lorentz force generated by the magnetic field permeating the material which is normally in the form of a disc, ring or rod. The orbiting particles form a very large (usually pulsed) current flow which can be extracted through the inductive coupling by a pick-up coil and used to perform useful work. This rotating additional current is generated at the expense of the energy extracted from the transmutation of the isotopes in the material of the disc, ring or rod. An alternative form of this process is the one used by Nikola Tesla and Alfred Hubbard where they used an already radioactive material such as Radium to trigger the cascade-carrier-multiplication process, instead of the NMR stimulation described here.

It must be stressed that no laws of physics, as we know them today, are violated here. The fuel is supplied by the material which forms the ring or rod. The device will not work forever and it is not free-energy, nor overunity (depending on how one defines it).

Please be fully aware that this analysis is for information purposes only and **must not** under any circumstances be considered to be a recommendation for you to build or experiment with any such device as lethal voltages are liable to be generated by the coils. Radioactive particles may be produced by this device. It may be necessary to mount any such device in an earthed box made of aluminium (or other suitable metal) in order to screen out any stray radioactive particles. The multiplication ring or disc should be grounded as the transmutation reactions produce a lot of charge. When not grounded, the voltage generated in the ring or disc can get very high and pose a danger of a fatal electric shock. The multiplication disc, ring or tube may overheat and even explode. Thus it is entirely your own responsibility should you decide to experiment with this kind of device.

The principles of operation of Kapanadze electromechanical devices.

by William J. McFreey - February 2012

Two recently released (although old) YouTube videos: <http://www.youtube.com/watch?v=3thvqFhFlfY> and <http://www.youtube.com/watch?v=qVUN3GsekKQ>, show a motor or electromechanical device designed by Tarel Kapanadze, running self-powered with a major mechanical output after being started with a tiny PP3 nine-volt battery only capable of providing a small current. The following analysis shows that Tarel's device is in fact, a dual, solid-state isochronous cyclotron-like device (<http://en.wikipedia.org/wiki/Cyclotron>) as shown here:

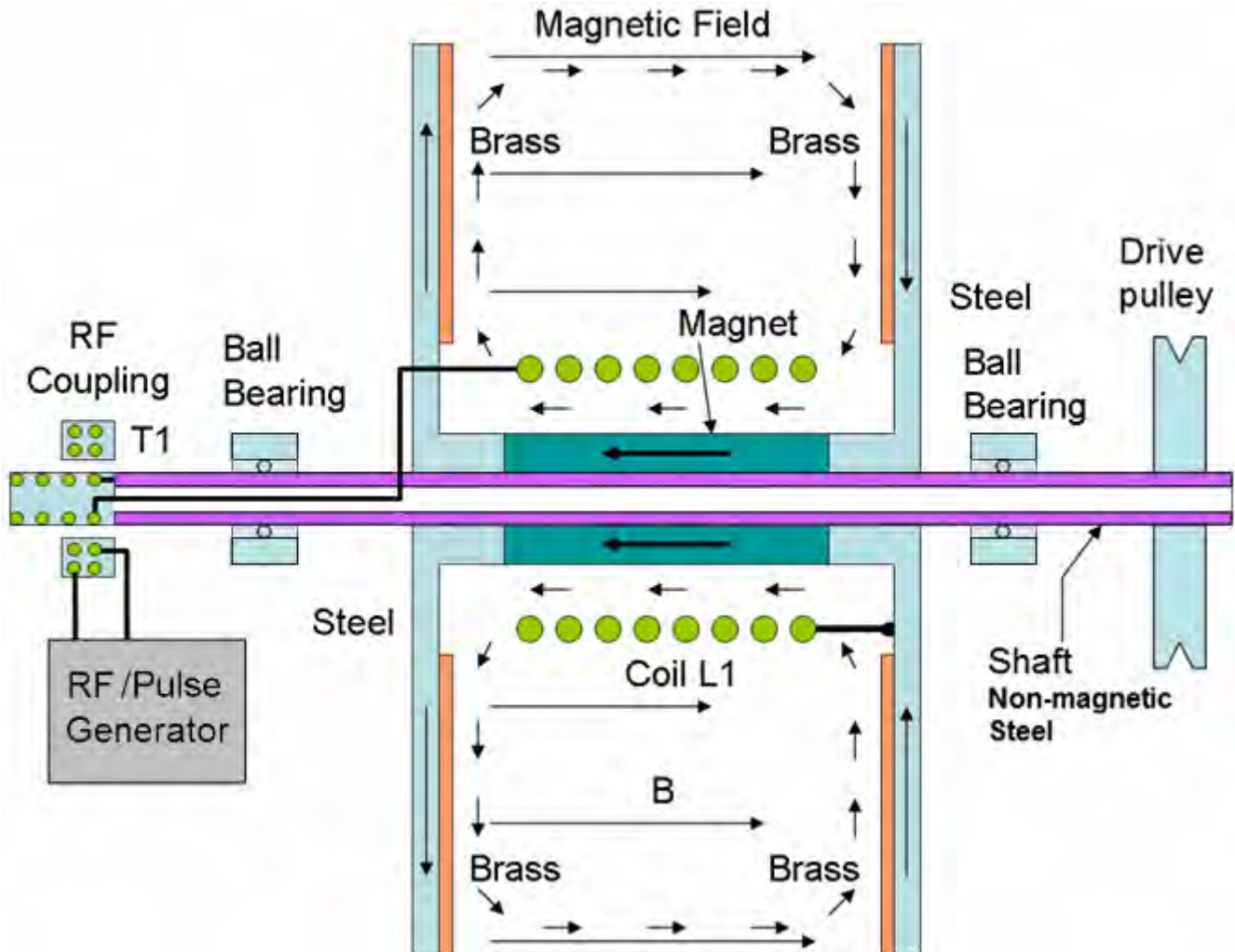

Fig.1. The cross-section of mechanical construction of the dual cyclotron-like device.

Some of the actual implementation details may differ from the arrangement shown above, but that should not alter the operation of device. The drawing above is not to scale.

The device consists of two identical composite discs mounted opposite each other on a shaft (the shaft should be grounded, as the discs produce significant amounts of charge during operation). The spacing between these two discs can be altered in order to adjust the magnetic field strength which is generated between the discs by the permanent magnet mounted on the axle shaft.

This toroidal magnet, which is marked with arrows in the drawing, is mounted on the shaft and positioned between the plates and it provides the necessary magnetic field between the steel flanges. Each disc consists of two materials: brass (or possibly copper) and magnetic steel. The brass parts of the discs face each other. The external transformer T1, is used to deliver radio-frequency energy to the steel/brass discs through the coil L1. This form of construction provides, not only the necessary magnetic field, but also a gradient in the magnetic field, as shown by the long black arrows in the drawing. The magnetic field passing through the brass plates is strongest at the perimeter of the discs due to the disc area there, while close to the shaft the magnetic field is practically zero, so the length of the black arrows in Fig.1, represents the strength of the magnetic field at that distance from the axle. In other words, the two steel flanges create a radially symmetrical and increasing distribution of the magnetic field. It should also be noted that one side of the brass discs is adjacent to a magnetic

field which has a component which is parallel to the plane of the disc. This may facilitate the lateral confinement of charged particles within the discs.

Each brass disc in this arrangement can act as an independent solid-state isochronous cyclotron-like device. There is a magnetic field perpendicular to the flanges and the strength of that field is proportional to it's distance from the axle. As an approximation, you can visualise it as there being a very large number of "cylinders" of equal magnetic strength between the flanges. The brass discs are immersed in this field. All that is missing to make this into a working isochronous cyclotron-like device are the fast-moving charged particles. These could be generated by using a radioactive material, but that is not necessary since in this case, they are generated through nuclear magnetic resonance-stimulated radioactivity. To accomplish this, the externally generated radio-frequency input signal is transmitted through the RF coupling transformer T1, to the coil L1. The signal returns through the steel plates and the non-magnetic shaft. The magnetic field created by coil L1 is radially parallel to the plane of the disc (marked schematically in Fig.1 by the small arrows) and therefore, perpendicular to the field within the disc, as is needed for NMR excitation. The radio frequency f_0 is chosen so that it will excite Nuclear Magnetic Resonance at the location of one of the cylinders of equal magnetic field between the flanges (see Fig.2). This frequency is given by

$$f_0 = \gamma B / (2\pi)$$

Where:

γ is the gyromagnetic ratio of an isotope in the disc material, and
 B is the local magnetic induction
(http://en.wikipedia.org/wiki/Nuclear_magnetic_resonance).

And the value of that magnetic field has to be such that the cyclotron resonance condition is also fulfilled, namely:

$$v = \frac{qBr}{m}$$

Where:

m is the particle mass,
 q is it's charge,
 B is, as before, the local magnetic induction,
 v is the particle's velocity, and
 r is the radius of the magnetic cylinder.

When the magnetic field strength at some radius fulfills both equations, then the action begins. Fast particles are generated by the Nuclear Magnetic Resonance-stimulated radioactivity in the brass discs and some of those particles will start to circulate in the plane of the discs where they get deflected and guided by the magnetic field, B , and follow a circular path on that cylinder of equal magnetic strength. The radius of the particle orbit is given by the equality of the centripetal force and the magnetic Lorentz force (http://en.wikipedia.org/wiki/Lorentz_force). This resembles an isochronous cyclotron action, although the particles are not accelerated, but instead, they are greatly increased in number.

The speed of these emitted radioactive particles is very high, being about 270,000 Km/s for beta particles, and this easily meets the cyclotron resonance requirement for moderate values of magnetic field, B , and the radius, r . The process can be sustained by the cascade-generation of many more fast particle emission events through elastic collisions (where the incoming particle is not absorbed in the collision) or inelastic collisions (where the particle is absorbed) of the particles with nuclei in the disc. The emission events become synchronised and unidirectional. More and more particles start circulating in the brass disc. In effect, this is a fast particle multiplier, where the fast particles create additional fast particles in a continuously repeating cycle. The exact reactions taking place in the disc and the particles involved in those reactions is beyond the scope of this article.

In theory, this creates a run-away condition. In reality, the circulating particles constitute a current in a one-turn coil with it's own magnetic field, which modifies the initial magnetic field B , and thus detunes the system from cyclotron-like and Nuclear Magnetic Resonance. In this way, the process saturates at a certain value of current, or, which is more common, enters a pulsation mode. The current created by the orbiting charged particles reduces the magnetic field in the discs, and pushes the cyclotron resonance orbit beyond the disc perimeter.

To explore this self quenching mechanism further, let us examine the direction of the multiplication current relative to the magnetising field (or current in the coil if used for magnetisation). To accomplish this, one needs to use the right-hand rule for the direction of the magnetic vector in a coil and a graphical illustration of the magnetic Lorentz force equation (these tools can be found for instance on Wikipedia). The conclusion is that the field produced by

the multiplication current will always oppose the magnetising field, thus reducing its strength. Subsequently, the cyclotron orbit radius increases to the point beyond the disc perimeter and the multiplication current vanishes.

The charge particle multiplication process resembles stimulated emission in masers or lasers, but on the particle level, rather than the photon level. Each particle emission event, under this condition, exerts a force on the emitting nucleus embedded in the disc material (the equivalent of a jet engine on a macroscopic scale), and so, significant torque is created.

Normally, the system is pre-tuned by adjusting the magnetic field B , to a value which will support cyclotron resonance on a cylinder of equal magnetic field B close to the perimeter of the brass discs, by estimating the effective speed of the charged particles which will be generated. When the Nuclear Magnetic Resonance stimulus is provided, cyclotron-like particle multiplication starts occurring and torque is generated, accompanied by a strong circular current in the brass discs. In this way, the arrangement of Fig.1 becomes a motor. When the Nuclear Magnetic Resonance stimulus is removed, the cyclotron-like multiplier process dies down, and hence the generated torque, ceases. In principle, the Nuclear Magnetic Resonance stimulus does not have to be very strong and can be generated by a small, battery powered solid-state generator. Unlike the Kapanadze coil, the generated high current in the discs is not utilised in this electromechanical device.

It is worth noting that gradient in the magnetic field, makes it easier to meet both Nuclear Magnetic Resonance and isochronous cyclotron resonance conditions. The magnetic field gradient also facilitates particle confinement within the discs.

The main problem in design of these devices is that the line-width of the nuclear magnetic resonance is very narrow. For instance, the full-width half-maximum (FWHM) line-width of the NMR in copper (Cu^{63} , Cu^{65}) is in order of 100 parts per million (ppm) (<http://chem.ch.huji.ac.il/nmr/techniques/1d/row4/cu.html>). This means that under a magnetic field that would make the nuclei of copper resonate at 1 MHz, the FWHM of this resonance would be ~100 Hz. The NMR line-width of zinc and iron is even narrower, on the order of 5 ppm (see other pages of the reference above). These facts make it difficult to find the exact NMR frequency and maintain the material in the disc under NMR resonance, especially when the magnetic field is not precisely stabilised. Therefore, it is advantageous to generate a dense comb of frequencies, rather than a single frequency, for the purpose of exciting NMR in the disc. This is accomplished by generating sharp pulse trains at a relatively low repetition rate. In this mode each pulse delivered to coil L1 produces a huge current pulse in the disc. The motor demonstrated by Kapanadze definitely used this principle.

As can be noticed in the videos, one of the discs is coated on the outside with a foamy substance. The magnetic force between the two loops of very high pulsed current in the discs excites mechanical vibration of the discs and this coating attenuates those vibrations.

Fast particles are generated in matter constantly as a result of spontaneous decay of nuclei. This generation is, however, not frequent enough to create avalanches of particles, even under the conditions described above. Here, the important requirement is that whenever the particle is absorbed, on average, it triggers the emission of more than one particle, and that the emitted particles move in the direction of the incoming particle. Thus, the circulating particles are not the same in the orbit as it is in a normal cyclotron. On the contrary, a charged particle's life-time in the disc is very short, and they are constantly being absorbed and regenerated at the expense of element transmutation within the material. However, between collisions, these particles are still subject to the Lorentz force.

In conclusion, the Kapanadze disc machines work on a principle of cyclotron-like resonance, but in conjunction with the radioactivity of certain conductive materials, when enhanced by Nuclear Magnetic Resonance stimulation.

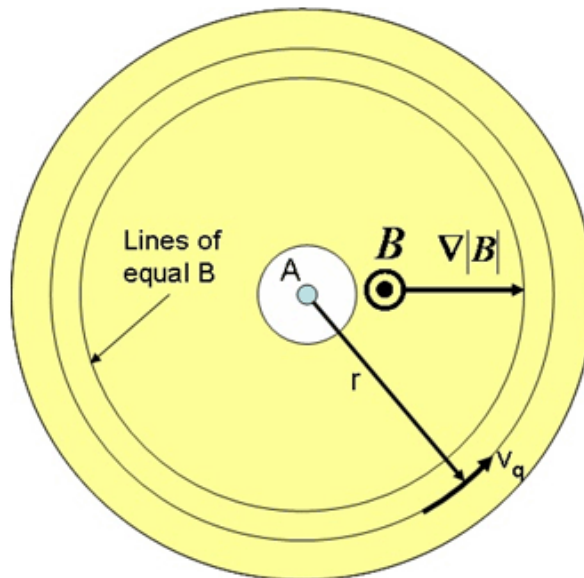

Fig.2. Gyration of the emitted charged particle in the gradient of the magnetic field in a disc (e.g. brass) under the condition of cyclotron resonance. The disc rotates in the opposite direction to the particles.

The choice of materials for the flange and disc construction is of extreme importance: in the flanges, magnetic steel is used to provide both strength and an even distribution of the magnetic field. For the discs, brass which is an alloy of Zinc and Copper both of which have many isotopes (<http://en.wikipedia.org/wiki/Brass>) or some other conductive material, like copper or even iron, is used in order to provide enhanced radioactivity under Nuclear Magnetic Resonance stimulation.

The physics behind all of Kapanadze's devices is the same and very interesting. It is stressed however, that no laws of physics, as we know them today, are violated here. The fuel is supplied by the disc material. The devices will not work forever and it is not free-energy, nor overunity (depending on how that is defined), but they are remarkable, both in their engineering and architecture.

These types of device were invented by Michel Meyer in the early 1970s (as can be seen earlier in this chapter and at <http://www.rexresearch.com/meyernmr/meyer.htm>), and developed further by Steven Mark in the mid 1990s (the shape of his first device was a spool). It is also possible that Nikola Tesla, and then Hubbard, experimented with this kind of device.

This analysis is for information purposes only and **must not** under any circumstances be considered to be a recommendation for you to build or experiment with any such device. Radioactive particles may be produced by this device. The centrifugal forces are extremely high in this device and so it is your full responsibility if you chose to experiment with this device. It may be necessary to mount any such device in an earthed aluminium box in order to screen out any stray radioactive particles.